



Rewarding Learning

ADVANCED
General Certificate of Education
2016

Centre Number

--	--	--	--	--

Candidate Number

--	--	--	--

Physics

Assessment Unit A2 3
Practical Techniques
Session 1



AY231

[AY231]

THURSDAY 5 MAY, MORNING

TIME

1 hour 30 minutes.

INSTRUCTIONS TO CANDIDATES

Write your Centre Number and Candidate Number in the spaces provided at the top of this page.

Turn to page 2 for further Instructions and Information.

For Examiner's use only		
Question Number	Marks	Remark
1		
2		
3		
Total Marks		

INSTRUCTIONS TO CANDIDATES

Answer **all** questions in this paper. Rough work and calculations must also be done in this paper. Except where instructed, do not describe the apparatus or experimental procedures. The supervisor will tell you the order in which you are to answer the questions. Not more than 30 minutes are to be spent in answering each question. You may be told to start with the experimental tests in Section A, or with the single question in Section B.

Section A consists of two experimental tests. A 28-minute period is allocated for you to use the apparatus. Two minutes are allocated to the supervisor to prepare the station for the next candidate. At the end of the 30-minute period you will be instructed to move to the area set aside for your next question. Section B consists of one question in which you will be tested on aspects of planning and design.

INFORMATION FOR CANDIDATES

The total mark for this paper is 60.

All questions carry 20 marks each.

Figures in brackets printed down the right-hand side of pages indicate the marks awarded to each part question.

You may use an electronic calculator.

Section A

- 1 In this experiment, two spring and string combinations, S_1 and S_2 , are suspended from a metre rule. You will investigate how the angle between S_1 and S_2 and the lengths of S_1 and S_2 change as the mass suspended from them is increased.

The aims of the experiment are:

- to measure the angle between S_1 and S_2 and the lengths of S_1 and S_2 as the mass, m , suspended from them is increased
- to plot a straight line graph
- to analyse the results and determine the value of a constant.

Apparatus

The apparatus has been set up for you as shown in **Fig. 1.1**. The distance between the points of suspension on the metre rule should not be adjusted.

A 100 g mass is suspended from S_1 and S_2 .

S_1 and S_2 have lengths l_1 and l_2 and the angle between S_1 and S_2 is θ .

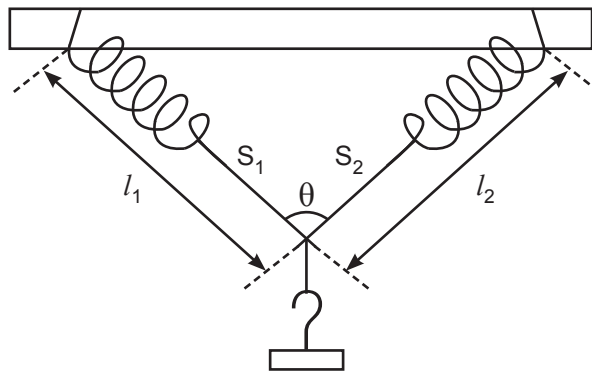

Fig. 1.1

- 2 In this experiment you will investigate how the intensity of light incident on a light dependent resistor (LDR) varies with the thickness of the glass through which the light is transmitted.

The aims of the experiment are:

- to measure the current through the LDR*
- to plot a graph to find the relationship between the current through the LDR and the thickness of glass through which the light is transmitted.

* The current through the LDR changes in proportion to the light intensity incident on the LDR.

Apparatus

- (a) The apparatus has been set up for you as shown in **Fig. 2.1**. There is a single microscope slide between the bulb and the LDR.

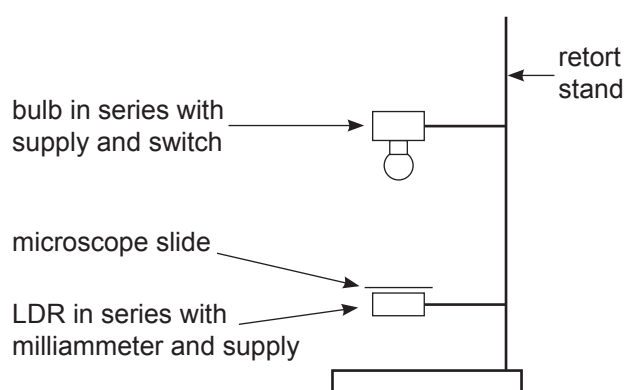

Fig. 2.1

Procedure

Close the switch and read the current, I , from the milliammeter.
Record your value in **Table 2.1** for number of slides, $N = 1$.

Repeat the procedure, adding microscope slides one at a time, up to a maximum of 5 slides. Record all of your measurements of current in **Table 2.1**. [3]

Table 2.1

N	I/mA	
1		
2		
3		
4		
5		

- (b) The relationship between the current, I , and the number of microscope slides, N , is given by **Equation 2.1**

$$I = I_0 e^{-PN} \quad \text{Equation 2.1}$$

where P and I_0 are constants.

- (i) Show that a graph of natural logarithm, $\ln I$, against N will result in a straight line graph from which values of I_0 and P can be determined.

[2]

- (ii) Calculate values for $\ln I$ to 2 decimal places and insert them into the remaining column of **Table 2.1**. Head the column in **Table 2.1** appropriately. [2]

Examiner Only

Marks Remark

(iii) Plot a graph of $\ln I$ against N on the grid of **Fig. 2.2** and draw a best fit straight line through the points. The N axis has been labelled and scaled.

[5]

Examiner Only	
Marks	Remark

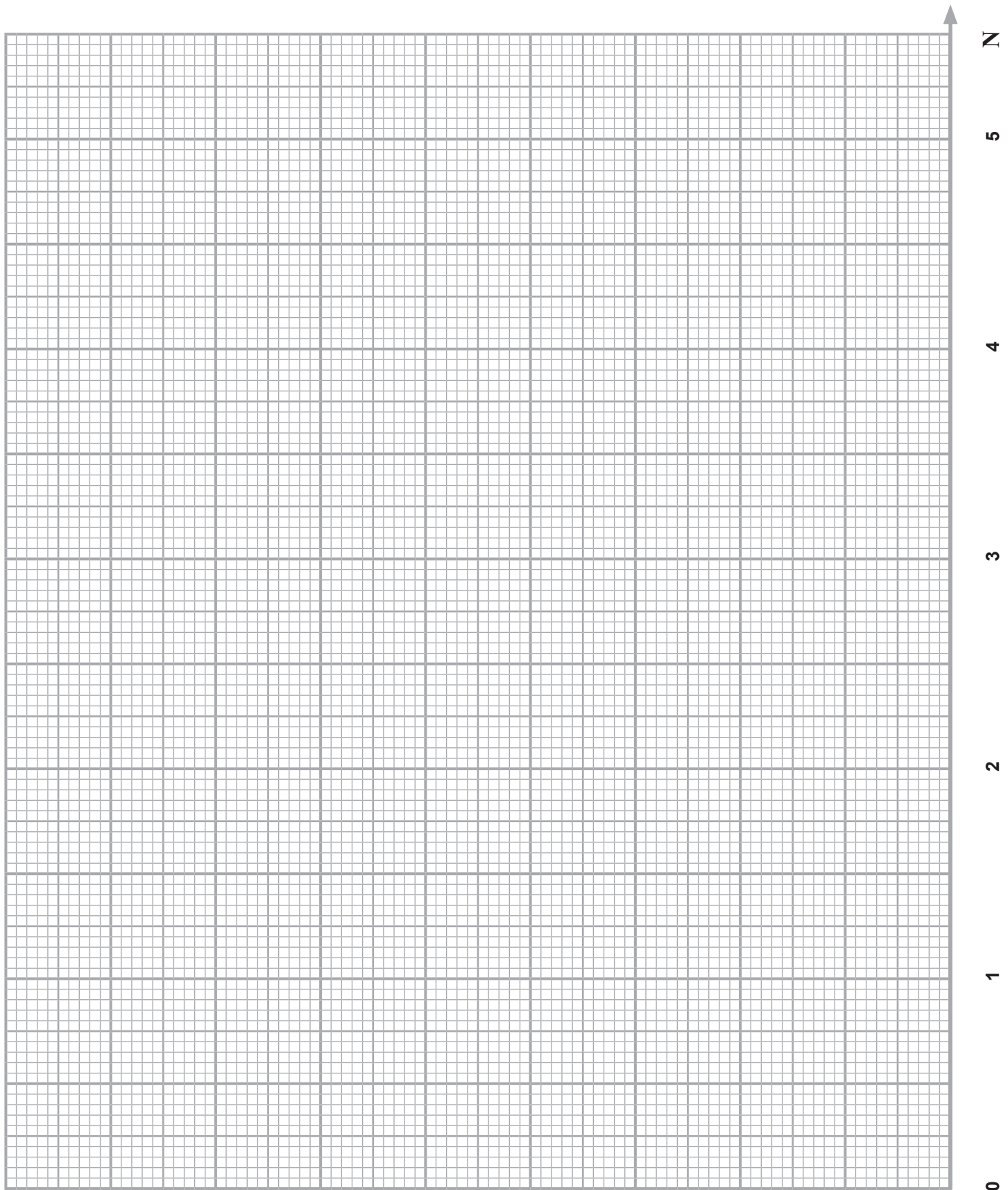

Fig. 2.2

BLANK PAGE

(Questions continue overleaf)

Section B

- 3 In this question you will plan an experiment to determine the radius of curvature of a bowl by measuring the period of oscillation, T , of a ball bearing as it oscillates in the bowl.

Fig. 3.1 shows a side view of the experimental arrangement.



Fig. 3.1

The period of oscillation of a ball bearing in the bowl is given by **Equation 3.1**

$$T = 2\pi\sqrt{\frac{7(R-r)}{5g}} \quad \text{Equation 3.1}$$

where R is the radius of curvature of the bowl, r is the radius of the ball bearing and g is the acceleration of free fall.

- (a) In order to check the validity of **Equation 3.1**, a student is given a bowl of radius of curvature 8.6 ± 0.1 cm. The student found the period of oscillation of a ball bearing to be 0.66 ± 0.05 s.

The ball bearing has a radius of 0.76 ± 0.01 cm.

- (i) Use the student's results to calculate a value for the acceleration of free fall.

Examiner Only	
Marks	Remark

$g =$ _____ m s^{-2}

[2]

[9]

Examiner Only	
Marks	Remark

THIS IS THE END OF THE QUESTION PAPER

Permission to reproduce all copyright material has been applied for.
In some cases, efforts to contact copyright holders may have been unsuccessful and CCEA
will be happy to rectify any omissions of acknowledgement in future if notified.



Rewarding Learning

ADVANCED
General Certificate of Education
2016

Physics

Assessment Unit A2 3
Practical Techniques
Sessions 1 and 2

[AY231] [AY232]
THURSDAY 5 AND FRIDAY 6 MAY

APPARATUS AND MATERIALS LIST

A2 PHYSICS UNIT 3 (A2 3)
APPARATUS AND MATERIALS REQUIRED FOR PRACTICAL ASSESSMENTS

CONFIDENTIAL

Information about the apparatus and materials required for the A2 Practical Assessments **must not** be communicated to candidates sitting the examination.

This document gives preliminary information on the apparatus and materials required for the A2 Practical Assessments.

Teachers will be given detailed instructions for setting up the experiments in the *Confidential Instructions for Physics (A2) Practical Tests*, to which they will have confidential access from March 2016.

Teachers will have confidential access to a copy of the experimental tests two working days (48 hours) before the start of the assessment.

The A2 3 Practical Techniques Assessment is a test of practical skills consisting of Section A and Section B. Section A comprises 2 experimental tests (40 marks) and Section B consists of one question which tests aspects of planning and design (20 marks). The duration of the assessment is 1 hour 30 minutes. Some of this time will be set aside for supervisors to re-set apparatus for the next candidates. In each of the experimental tests (Q1 and Q2), candidates must stop using the apparatus after 28 minutes. At the end of each 28 minute period, a changeover time of 2 minutes will be set aside for the supervisor to re-set the apparatus for the next candidates. During the changeover periods, candidates may write-up anything they have not completed, however they will not have access to the apparatus. Candidates will move on to the next question after 30 minutes. The time allocation for **question 3** (planning and design) is 30 minutes. As the time allocation for each question is effectively the same, the supervisor can decide in which order the candidates should attempt the questions.

The apparatus in the following list will allow for **one experiment** to be set up for each of the practical tests which make up **questions 1 and 2**. In other words, each set of apparatus (as listed on page 4) will accommodate three candidates.

The apparatus can be used for alternative sessions according to the following schedule:

5 May 2016 Physics A2 3A (AY231)

(Main Session) **9.15 am–10.45 am**
(First Alternative) **11.00 am–12.30 pm**
(Second Alternative) **1.15 pm–2.45 pm**
(Third Alternative) **3.00 pm–4.30 pm**

6 May 2016 Physics A2 3B (AY232)

(Main Session) **9.15 am–10.45 am**
(First Alternative) **11.00 am–12.30 pm**
(Second Alternative) **1.15 pm–2.45 pm**
(Third Alternative) **3.00 pm–4.30 pm**

One set of apparatus for A2 3A (AY231) will therefore be sufficient for twelve candidates on **5 May** if the Main Session and all three alternatives are used. Similarly, one set of apparatus for A2 3B (AY232) will be sufficient for twelve candidates on **6 May** if the Main Session and all three alternatives are used. A laboratory may contain one, two, three or more sets of apparatus. This means that three, six, nine or more candidates can be accommodated in the same session. **When alternative sessions are used care must be taken to segregate candidates who have taken the examination from those who have still to sit the examination.**

IMPORTANT NOTICE

Centres are urged to order items needed for the Physics Practical Tests from the suppliers as soon as possible.

Question 1

Ref.	Component	Session 1	Session 2
1.1	Retort stand	1	1
1.2	Boss & clamp	1	1
1.3	Metre rule	1	1
1.4	String	✓	✓
1.5	Helical spring \approx 25 mm length	2	2
1.6	100 g mass hanger	1	1
1.7	100 g slotted mass	4	4
1.8	Protractor	1	1
1.9	Masking tape	✓	✓
1.10	Half-metre rule	1	1

Question 2

Ref.	Component	Session 1	Session 2
2.1	1.5 V cell	2	1
2.2	1.5 V cell holder	2	1
2.3	Milliammeter (to 0.01 mA or 0.1 mA)	1	1
2.4	Leads 4 mm	7	7
2.5	2.5 V bulb	1	0
2.6	Bulb holder with 4 mm sockets	1	1
2.7	Switch	1	1
2.8	LDR (e.g. Rapid NORPS 12)	1	1
2.9	6 V supply	1	1
2.10	Microscope slide (0.8–1.0 mm thick)	5	5
2.11	Retort stand	1	1
2.12	Boss & clamp	2	2
2.13	1.5 V bulb	0	1

Question 3

No equipment is required for this question.



Rewarding Learning

ADVANCED

General Certificate of Education

2016

Physics

Assessment Unit A2 3

Practical Techniques

Sessions 1 and 2

[AY231] [AY232]

THURSDAY 5 AND FRIDAY 6 MAY

**CONFIDENTIAL
INSTRUCTIONS
TO
TEACHERS**

CONFIDENTIAL INSTRUCTIONS FOR PHYSICS A2 PRACTICAL TEST

Confidentiality

To maintain the integrity of the Test, no question papers or any material pertaining to the Test should be publicly released until after the final session.

General

The Practical Test will contain three compulsory questions, of which two are 30-minute experimental tests and the third is a 30-minute question testing Planning and Design. The total time allowed is 1 hour 30 minutes. The order in which candidates are to take the questions is to be decided by the Supervisor. Candidates will have access to the apparatus in the experimental tests for 28 minutes each, the final two minutes being reserved for adjustment of the apparatus by the Supervisor. The question paper includes spaces for answers; candidates will write their answers in the Question/Answer booklet.

Question 1

Ref	Component	Session 1	Session 2
1.1	Retort stand	1	1
1.2	Boss & clamp	1	1
1.3	Metre Rule	1	1
1.4	String	✓	✓
1.5	Helical spring ≈ 25 mm length (similar spring constants)	2	2
1.6	100 g mass hanger	1	1
1.7	100 g slotted mass	4	4
1.8	Protractor	1	1
1.9	Masking tape	✓	✓
1.10	Half-metre rule	1	1

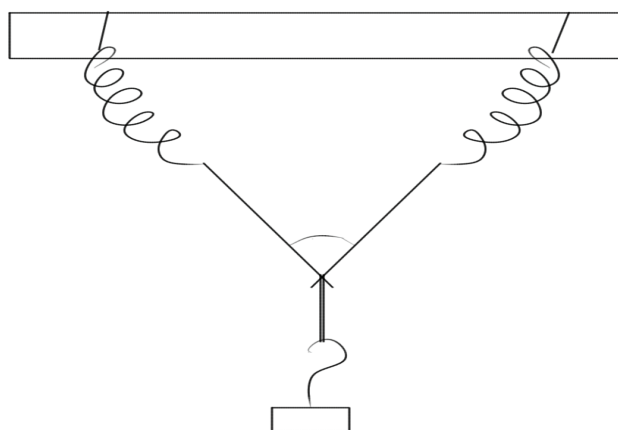

Fig. 1.1

Tie a spring to each end of a length of string so that the total length of string + springs = 40 ± 1 cm.

Tie a small loop of string onto the centre point of the string from which a mass hanger can be hung.

Before the Examination

Clamp the centre of the metre rule to the retort stand.

Use string to attach the other end of the springs to the metre rule as shown in **Fig 1.1**. Set the distance between the loops of string on the metre rule to 35 ± 1 cm. Tape the strings to the metre rule so they can't be moved.

Ensure that a mass of 500g can be suspended from the string so that it can hang freely without the mass hitting a surface.

Place the mass hanger on the string and leave the remaining 4×100 g masses along with the protractor and half-metre rule close to the apparatus.

Action at Changeover

Ensure that the distance between the loops of string on the metre rule is 35 cm.

Hang the 100 g mass hanger from the string.

Arrange all other apparatus as Before the Examination.

Question 2

Ref	Component	Session 1	Session 2
2.1	1.5 V cell	2	1
2.2	1.5 V cell holder	2	1
2.3	Milliammeter (± 0.01 mA or ± 0.1 mA)	1	1
2.4	Leads 4 mm	7	7
2.5	2.5 V bulb	1	0
2.6	Bulb holder with 4 mm sockets	1	1
2.7	Switch	1	1
2.8	LDR (Rapid (NORPS 12))	1	1
2.9	6V supply	1	1
2.10	Microscope slide (0.8–1.0 mm thick)	5	5
2.11	Retort stand	1	1
2.12	Boss & clamp	2	2
2.13	1.5 V bulb	0	1

Connect the bulb to a switch and two 1.5 V cells (Session 1). [One 1.5 V cell Session 2]

Connect the LDR to a 6V supply and milliammeter.

Before the Examination

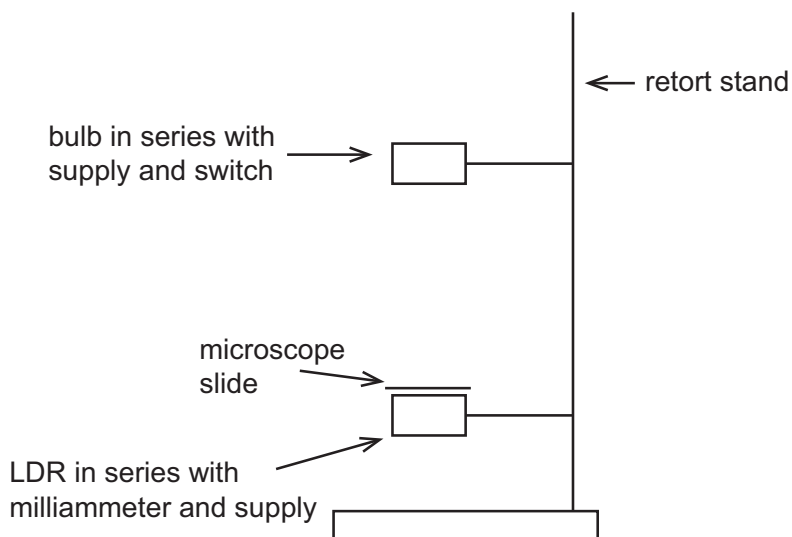

Clamp the LDR in the bottom clamp of the retort stand (with its surface horizontal and) facing upwards.

Clamp the bulb in the top clamp of the retort stand and facing downwards. The distance between the LDR and the bulb should be 2–3 cm.

Place 1 microscope slide on top of the LDR, between the LDR and the bulb, and resting on the jaws of the bottom clamp.

Action at Changeover

Place 1 microscope slide on top of the LDR, between the LDR and the bulb.

Question 3

No equipment is required for this question.

